

217-9191-751

Victor SPX User Guide

Victor SPX

User Guide

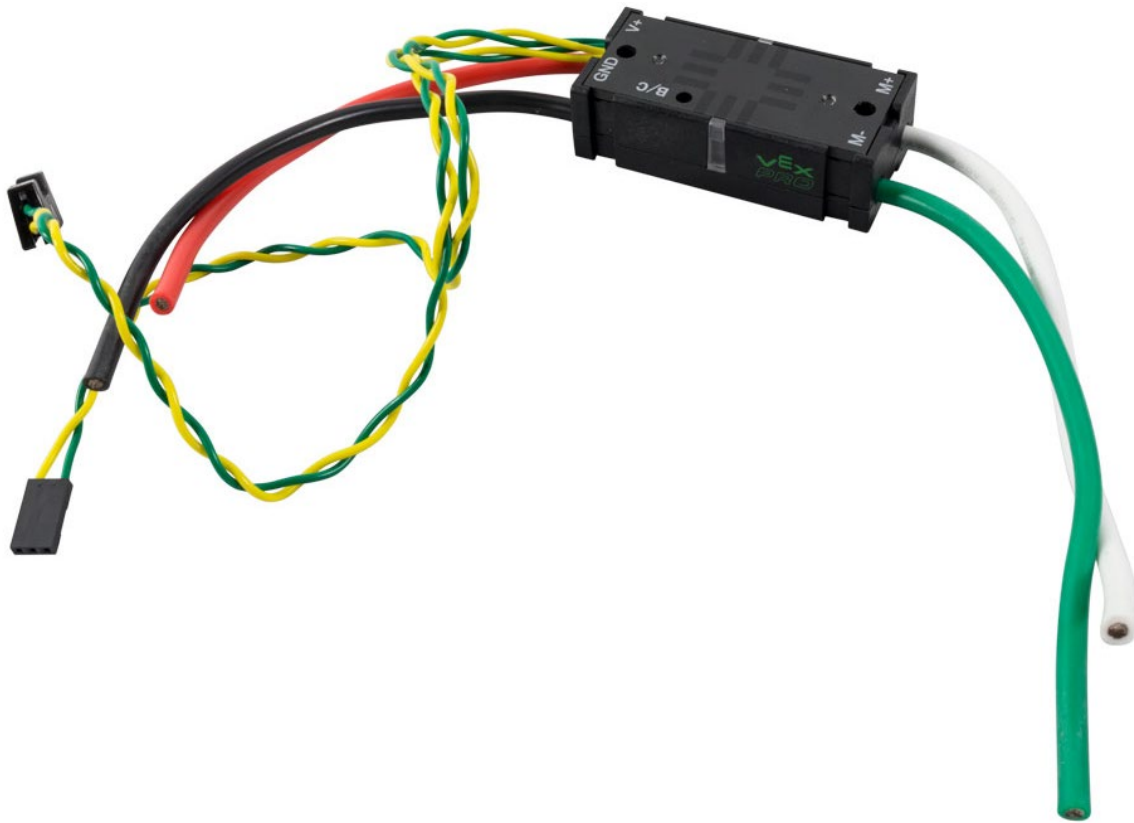

VEX
PRO

 vexpro.com  ctr-electronics.com

Copyright 2018, VEX Robotics Inc., Cross the Road Electronics
Updated: 2021-11-29

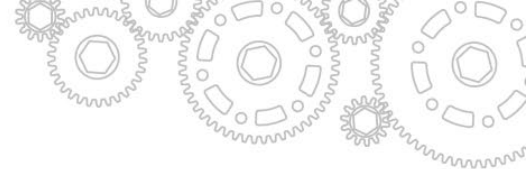

Table of Contents

The Victor SPX at a Glance.....	3
Installing the Victor SPX.....	4
Wiring the Output.....	4
Wiring the Input.....	4
Controlling the Victor SPX.....	5
CAN bus	5
PWM	6
Mounting the Victor SPX	7
Strain Relief	8
Applying Power for the First Time.....	8
Additional Information	9
Brake & Coast Modes.....	9
Calibration	10
Blink Codes.....	11
Thermal Performance.....	12
Frequently Asked Questions:.....	13
Troubleshooting	16
FCC Compliance Statement (United States).....	19
ICES-003 Compliance Statement (Canada).....	19
Revision History.....	19

Getting Started – Victor SPX

The Victor SPX is a speed controller designed through collaboration between VEX Robotics (vexrobotics.com) & Cross the Road Electronics (ctr-electronics.com) that allows for fine control and high performance of brushed DC motors in competition robotics applications. The Victor SPX handles high current loads with minimal voltage drop and heat generation. Its linear output and Brake/Coast options allow for precise motor control, making it well suited for all FRC motor applications from drivetrains to shooter wheels. The plastic housing and aluminum heatsink create a lightweight motor controller – while maintaining the full sealed, fan-less design that FRC teams expect. This, combined with a 3 sq-in. footprint, a variety of built-in mounting options and super flexible, high strand count leads make installation a breeze.

The Victor SPX at a Glance:

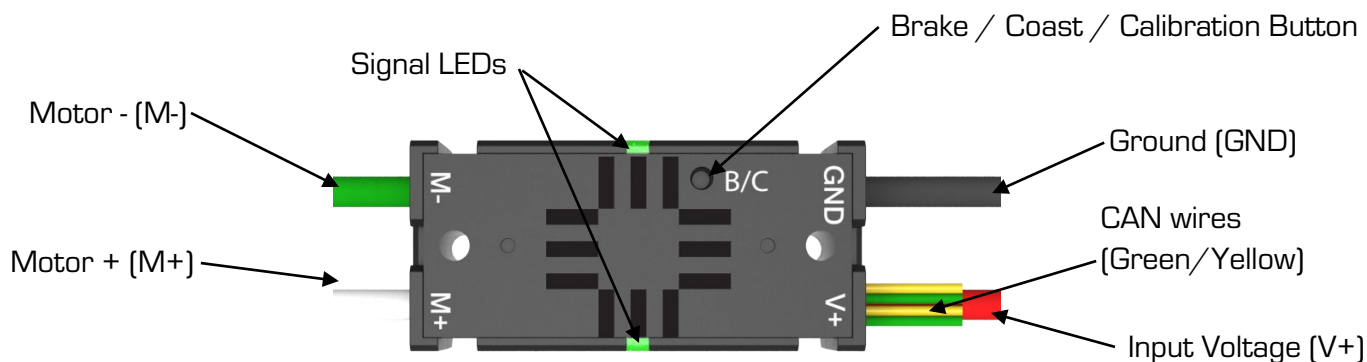

Victor SPX Specs	
Outside Dimensions	2.50" x 1.16" x 0.77" [63.5mm x 29.5mm x 19.5mm]
Weight (Without Wire)	0.20 lbf [0.09 kgf]
Nominal Voltage	12 VDC
Min/Max Voltage	6-16 VDC
Continuous Current	60A
Surge Current (2 sec)	100A
PWM Input Pulse (High Time)	1 - 2 ms Nominal
PWM Input Rate (Period)	2.9 - 100ms
PWM Output Chop Rate (Switching Frequency)	15.625 kHz
PWM Logic High Min. Voltage Threshold	1 VDC
PWM Logic Low Max. Voltage Threshold	0.4 VDC
PWM Input Min. Current	<1mA
Minimum Throttle (Deadband)	Adjustable [0.1% - 25% (4% Default)]

Victor SPX User Guide

The power input & outputs of the Victor SPX are indicated by markings on the housing as well as wire color as shown in the table below. All power input/output wires on the Victor SPX are 600 strand minimum, 12AWG copper wire.

Wire	Case Marking	Wire Color	Wire Length
Positive Input	V+	Red	5.5in [139.7mm] ± 0.25in [6.35mm]
Input Ground	GND	Black	5.5in [139.7mm] ± 0.25in [6.35mm]
Motor Positive	M+	White	5.5in [139.7mm] ± 0.25in [6.35mm]
Motor Negative	M-	Green	5.5in [139.7mm] ± 0.25in [6.35mm]
CAN-High / PWM Signal	None	Yellow	12.0in[304.8mm] ± 0.25in [6.35mm]
CAN-Low / PWM Ground	None	Green	12.0in[304.8mm] ± 0.25in [6.35mm]

Installing the Victor SPX

Wiring a speed controller has never been easier than with the Victor SPX. By following a few quick steps, your robot will be up and running in no time.

Wiring the Output

Connect the white wire to the M+ side of the motor and the green wire to the M- side of the motor using tightly crimped connectors. If the motor's inputs are not marked, the polarity of the input may be chosen by the user. Be sure to connect the output wires to motors with consistent polarity so each motor will rotate the same direction when given the same CAN bus command or PWM signal. Reversing the output wire connections will result in the motor rotating the opposite direction when given the same CAN bus command or PWM signal.

In many cases, the output leads of the Victor SPX will not be long enough to reach the motor it is controlling, so an extension cable will be required. Extension cables should be made using appropriately sized wire and connected using properly crimped connectors.

Note: For the most robust connection, it is **highly** recommended that all connectors are crimped **and** soldered.

Wiring the Input

To power the Victor SPX, connect the positive input (red) wire to the selected positive terminal of the Power Distribution Panel (PDP), and the input ground (black) wire to the corresponding ground terminal. In many cases, the Victor SPX may be wired directly to the robot's PDP without extension cables – this is preferable since it reduces the number of electrical connections. If the

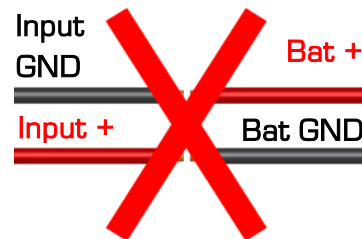

Victor SPX User Guide

robot's design does not allow for a direct connection to the PDP, extension cables may be used.

Always keep good electrical practices in mind when designing a robot's electrical system. The Victor SPX's source voltage should never exceed 28V. In addition, a 40A or smaller breaker should be used in series with the Victor SPX's positive input.



WARNING: TO MAXIMIZE PERFORMANCE, THE VICTOR SPX DOES NOT INCLUDE REVERSE POLARITY PROTECTION. IF POWER IS APPLIED BACKWARDS, THE VICTOR SPX MAY BE PERMANENTLY DAMAGED.

Controlling the Victor SPX

The Victor SPX was intended to be a drop-in replacement for the Victor SP, allowing teams to use either basic control over PWM – or make the jump to more advanced control over CAN bus. To make this easier for teams, we've included a standard 3 pin (0.1" pitch) connector on each of the Green/Yellow twisted pairs. One set of wires has a female connector and the other has a male connector.

CAN bus

Using the CAN bus to control the Victor SPX allows users to take full advantage of all its features. To wire the CAN bus, connect a yellow signal wire to the CAN terminal marked "H" on the NI roboRIO and connect a green signal wire to the CAN terminal marked "L" on the NI roboRIO.

To connect additional Victor SPXs, use tightly crimped connectors to connect the signal wires green-to-green & yellow-to-yellow as shown below. For the best connection, it is **highly** recommended that each connector is crimped **and** soldered. The yellow and green wires should also be wrapped in a twisted pair fashion (not illustrated) to maximize tolerance to electrical noise.

Note: Signal wires of the same color are electrically identical – it does not matter which wire is used as long as the color is correct.

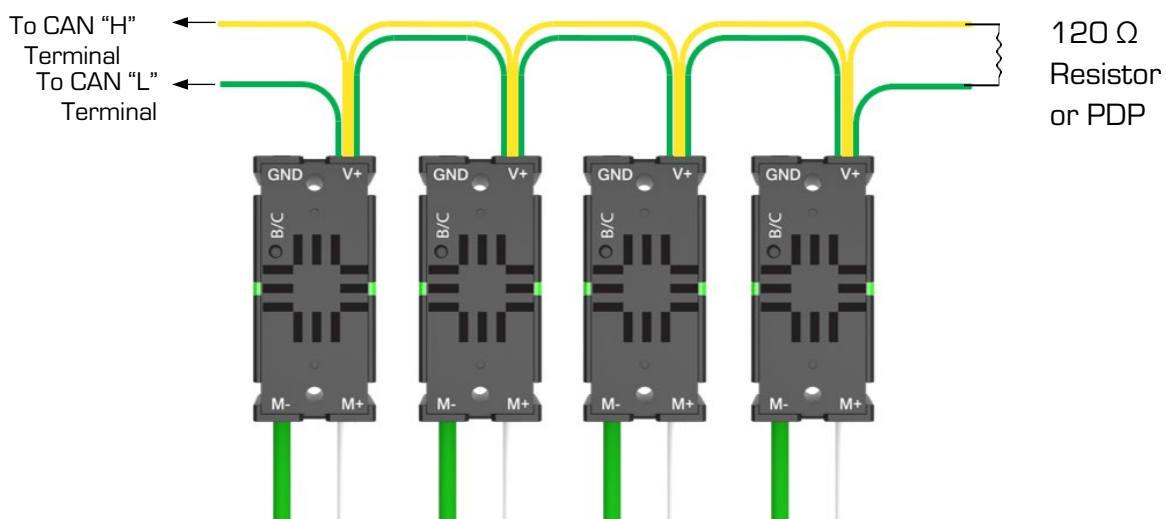

Victor SPX User Guide

After your Victor SPXs have been wired, there will be 2 remaining signal wires – connect these two wires using a 120 Ω resistor or to the CAN interface on the Power Distribution Panel (PDP) to properly terminate the cable end.

PWM

Either of the Victor SPX's built-in CAN bus wires can be used to control the device using PWM. In addition, one set of twisted pair wires have a male PWM connector while the other has a female PWM connector. This makes it easy to connect the Victor SPX with many PWM controllers, such as the roboRIO and several VEX microcontrollers. The PWM signal used to control the Victor SP should be between 1-2ms in duration with a center (neutral) pulse of 1.5ms and a period between 2.9-100ms. The PWM period is how fast the robot controller can send a new PWM pulse. The amount of time between the rising edge of one PWM pulse to the next PWM pulse should not be less than 2.9ms or greater than 100ms.

The pinout for the Victor SPX's PWM cable is shown in the table below:

Wire Color	Description	Traditional PWM Wire Color
Yellow	PWM Signal	White
Green	PWM Ground	Black

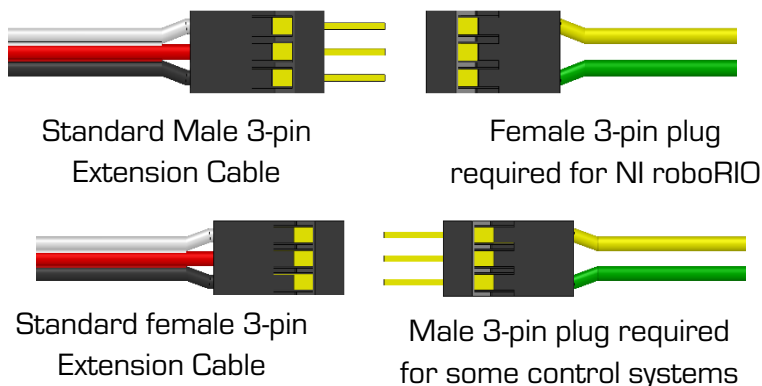

Controlling a Victor SPX with a NI roboRIO Controller:

To connect a Victor SPX to the NI roboRIO controller, simply plug the Victor SPX's attached female PWM connector into the desired PWM header in the roboRIO's PWM output with the yellow (signal) wire on the "inside" of the controller. If an extension cable is needed for the Victor SPX to reach the roboRIO, a standard male-female 3-wire extension cable should be used – these extension cables are available from VEX Robotics as well as many other online retailers.

Victor SPX User Guide

Controlling a Victor SPX with a VEX Microcontroller:

The Victor SPX is compatible with the following VEX microcontrollers:

- VEX V5 Robot Brain
- VEX ARM® Cortex®-based Microcontroller
- VEX PIC Microcontroller V0.5
- VEXpro ARM9 Microcontroller

To connect a Victor SPX with any of the above VEX microcontrollers, simply plug the Victor SPX's male PWM connector into the desired motor port on the microcontroller with the white (signal) wire on the "inside" of the microcontroller.

If an extension cable is needed for the Victor SPX to reach one of these microcontrollers, a standard male-female 3-wire extension cable should be used – these extension cables are available from VEX Robotics as well as many other online retailers.

Note: The Victor SPX's default calibration profile is configured for use with the roboRIO. To reconfigure it for use with a VEX microcontroller, follow the directions in the Calibration section.

Mounting the Victor SPX

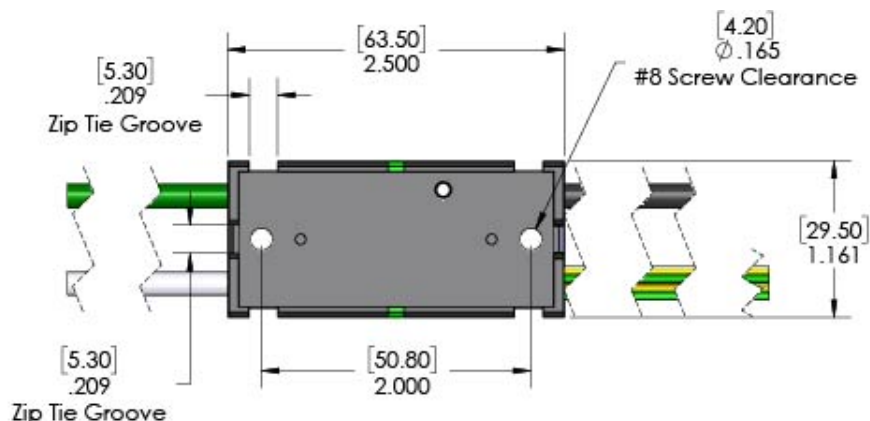

The Victor SPX can be mounted using either (2X) #8-32 screws or zip-ties. The Victor SPX's aluminum and plastic case is electrically isolated from the electronics, meaning it is safe to mount directly to a robot's frame!

The Victor SPX's mounting location should be chosen to allow for adequate air flow around the housing and sides of the case. Any Victor SPXs that are used for low-current applications may be stacked as shown below, but Victor SPXs used for high current applications, such as drivetrains, should be mounted individually.

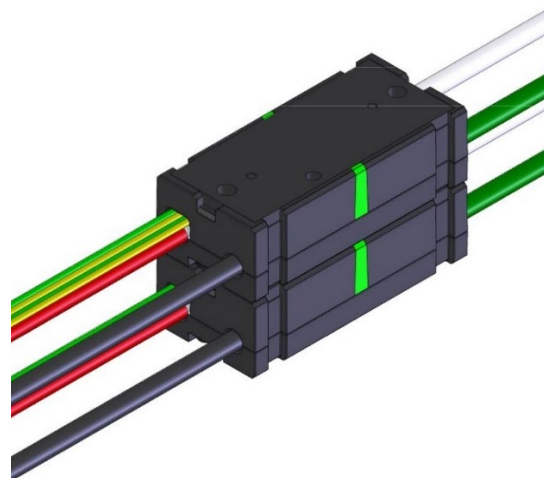

For maximum heat dissipation, it is recommended that the Victor SPX be securely mounted to a robot's metal frame – this allows the robot to be used as a giant heatsink to aid in cooling.



CAUTION: IN RARE CIRCUMSTANCES, THE VICTOR SPX MAY BECOME HOT DURING USE. USE CAUTION AROUND ANY VICTOR SPX THAT HAS RECENTLY BEEN USED, ESPECIALLY ONES USED FOR HIGH CURRENT APPLICATIONS. IF PROTECTED BY A 40A BREAKER, THE VICTOR SPX MAY BECOME HOT BUT WILL NOT BECOME HOT ENOUGH TO DAMAGE ITSELF.

Strain Relief

An important yet frequently forgotten aspect of wiring is strain relief. All electrical connections should be isolated from any pulling or tugging that may result in a poor connection. Once the Victor SPX is fully wired, zip ties should be used to ensure that all electrical connections are protected.

Note: When zip-tying wires down, it is crucial to avoid sharp edges on the robot. Wires that are anchored to sharp edges can become worn over time and cause a short.

Applying Power for the First Time

Before applying power for the first time, it is a good idea to double check the following:

- The red wire is connected to the positive source
- The black wire is connected to the source ground
- All electrical connections are secure and electrically isolated
- A 40A or smaller breaker is in series with the Victor SPX's positive power input
- There are no short circuits on the Victor SPX's output
- The CAN cable is correctly oriented (i.e. yellow to yellow for CAN bus & yellow to white for PWM)

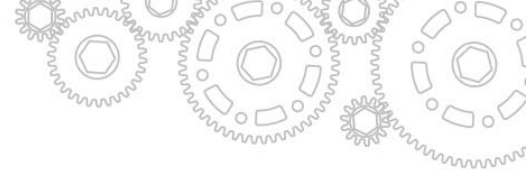

Additional Information

Brake & Coast Modes

The Victor SPX has two modes: Brake and Coast. When a neutral signal is applied to the Victor SPX in Brake mode, the motor will resist rotation, especially high-speed rotation. This is accomplished by essentially shorting the motor leads, which causes a Back Electromotive Force (Back-EMF) to resist the rotation of the motor. Brake mode does not have any effect when the motor is not rotating, but can make a large difference in robot behavior when used on a motor attached to a high reduction gearbox. Brake mode does not impact performance when a non-neutral signal is applied.

When a neutral signal is applied to the Victor SPX in Coast mode, Back-EMF will not be generated, so the motor's rotation will not be affected by the Victor SPX.

Switching between Brake & Coast:

To switch between Brake and Coast mode, simply push the B/C CAL button at any time. The Victor SPX is in Brake mode when the button is illuminated red and Coast when the red light is turned off. Brake/Coast settings are saved even if power is removed from the Victor SPX.

Victor SPX User Guide

Calibration

The calibration of a Victor SPX is essentially the scale of input signal to output voltage. Different controllers may have different “max” and “min” signals that may not correspond to the same Victor SPX outputs. Calibrating the Victor SPX allows it to adjust for these differences so that a “max” signal results in a “max” output. Calibrating can also correct issues caused by joysticks or gamepads with off-center neutral outputs. The Victor SPX’s default calibration is compatible with the roboRIO control system.

To Calibrate the Victor SPX:

- 1) Press and hold the B/C CAL button until the Status LEDs begin to rapidly blink red & green.

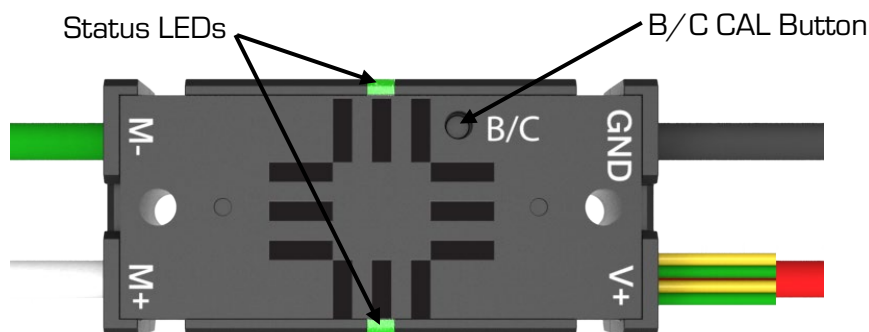

- 2) While holding the button, move the joystick (or other input signal) to full forward then to full reverse. This can be done multiple times. The Victor SPX is looking for max & min PWM values during this step, so ensure that the joystick reaches its full max and full min.
- 3) Release the joystick and allow it to return to neutral. After the joystick is in the neutral position, release the B/C CAL button.
- 4) If the Victor SPX was calibrated properly, the status LEDs will blink green several times. If the calibration failed, the status LEDs will blink red and the previous calibration will be kept.

Note: Calibration profiles are saved even if power is removed from the Victor SPX.

To Restore Default Calibration:

- 1) Remove power from the Victor SPX
- 2) Hold down the B/C CAL button
- 3) While holding down the button, restore power to the Victor SPX
- 4) Continue holding the button until the status LEDs blink green, then release the button

Blink Codes

Blink Codes During Calibration	
Status LEDs Blink Code	Victor SPX State
Flashing Red/Green	Calibration Mode
Blinking Green	Successful Calibration
Blinking Red	Failed Calibration

Blink Codes During Normal Operation		
LEDs	Colors	Victor SPX State
Both	Blinking Green	Forward throttle is applied. Blink rate is proportional to Duty Cycle
Both	Blinking Red	Reverse throttle is applied. Blink rate is proportional to Duty Cycle
None	None	No Power is being applied to Talon SRX
LEDs Alternate ¹	Off/Orange	CAN Bus detected, robot disabled
LEDs Alternate ¹	Off/Slow Red	CAN/PWM is not detected
LEDs Alternate ¹	Off/Fast Red	Fault Detected
LEDs Alternate ¹	Red / Orange	Damaged Hardware
LEDs Strobe "towards" (M+) ²	Off/ Red	Forward Limit Switch or Forward Soft Limit
LEDs Strobe "towards" (M-) ²	Off/ Red	Reverse Limit Switch or Reverse Soft Limit
LED1 Only	Green / Orange	In Bootloader

B/C CAL Button Blink Codes	
B/C CAL Button Color	Victor SPX State
Solid Red	Brake Mode
Off	Coast Mode

- 1) LEDs alternate – Status LEDs are different colors at all times. The {2X} LEDs will swap colors when blinking.
- 2) {1X} Status LED will blink followed shortly by the other with a long pause before repeating. The "direction" of the blink indicates the Talon SRX's current state.

Thermal Performance

To evaluate the Victor SPX's thermal performance, a 40A load was applied using CIM motors and a dynamometer. Before the test, a thermocouple was attached to the top of the Victor SPX PCBA. The test was run for 15 minutes at 50% duty cycle. After the motor controller returned to room temperature, the test was re-run at 100% duty cycle. During both tests, temperature data was recorded at regular intervals. The results are plotted below.

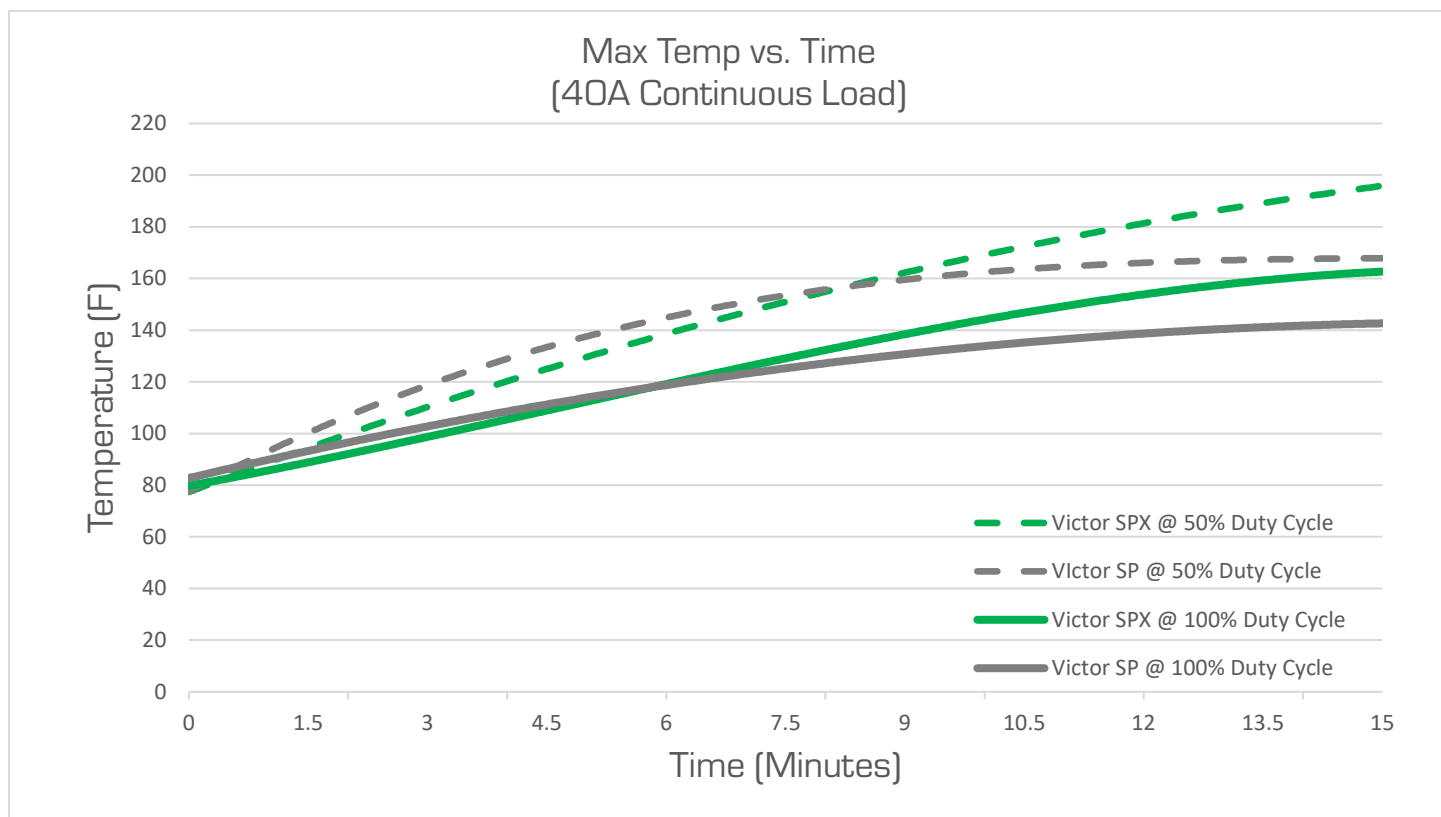

Note: Running a motor controller at 50% duty cycle causes the transistors to switch at a higher frequency. This switching is what produces the most heat.

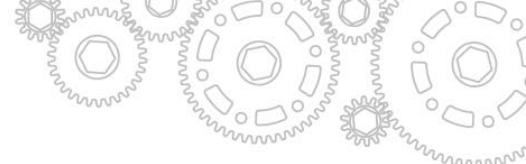

Frequently Asked Questions:

Q: Is it possible to use more than one type of speed controller?

A: Yes, it is completely safe and acceptable to use multiple types of speed controllers on a single robot.

Q: Is it safe to mount a Victor SPX directly to a robot's metal frame?

A: It is not only safe, it's recommended. The electronics inside the Victor SPX are in a plastic housing, with a layer of insulation between the electronics and the aluminum heatsink. Mounting a Victor SPX to a robot's frame allows the robot to be used as a giant heatsink that will help keep the Victor SPX cool.

Q: Does the Victor SPX require a fan?

A: The Victor SPX does not require a fan for typical FRC use, but if the robot is being used for practice or many back to back matches it is a good idea to use a fan to cool the Victor SPX.

Q: What kind of electrical connectors should I use to connect wires to the Victor SPX?

A: The choice of electrical connectors is left to the user. Electrical connectors used with the Victor SPX should be designed for use with 12AWG wire and tightly crimped. For the best electrical connection, it is highly recommended that wire connectors are soldered to the wire they are crimped on.

Q: Can the Victor SPX be used with control systems other than the NI roboRIO?

A: Yes, the Victor SPX may be used with any control system that is capable of PWM output or CAN bus.

Q: There isn't a wire connected to the center (red) PWM wire on the .1" servo connector, is this a problem?

A: No. The center (red) PWM wire is typically +5V that can be used to power PWM devices. The Victor SPX is powered by the 12V input and does not require PWM power.

Q: What CAN bus topologies are recommended?

A: The Victor SPX is intended to be used in the **daisy chain fashion**. Additionally, FRC Teams should always confirm what is considered "legal" per latest FRC competition rules.

Victor SPX User Guide

Alternatively, the CAN bus may be wired in the fashion commonly seen in the automotive industry, where a single harness is made (with proper termination resistor at each of the two ends). Each module can “tap” into the primary bus harness (crimp, connector, soldered, etc.) with a cable stub (maximum length of one foot).

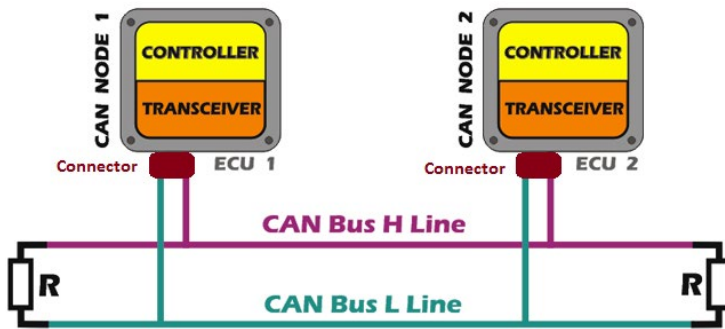
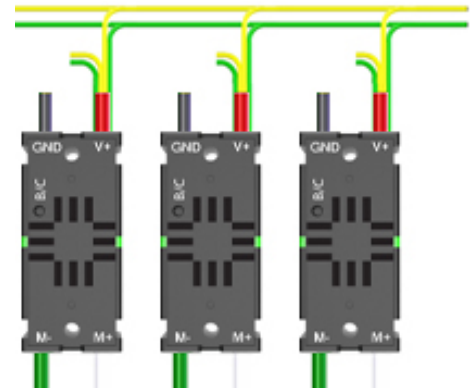

In the automotive industry, this is accomplished with a cable design that has the cable stubs designed in with end-connectors at various places in the cable.

As documented in the DW CAN bus specification, both daisy chain or a designed master cable harness meets the specification’s documented topology (diagram below).

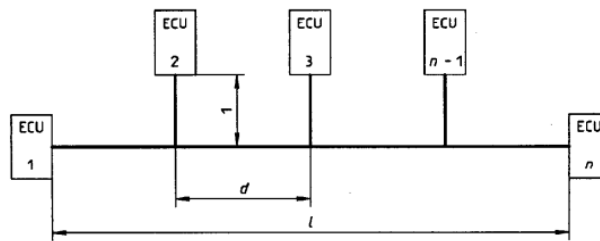

Figure 22 — Wiring network topology

Table 15 — Network topology parameters

Parameter	Notation	Unit	Value			Conditions
			min.	nom.	max.	
Bus length	L	m	0		40	
Cable stub length ¹⁾	l	m	0		0,3	Bit rate: 1 Mbit/s ²⁾
Node distance	d	m	0,1		40	

1) Dependent on the topology, the Baud rate, and the slew rate deviations from 120 Ω may be possible. It is, however, necessary to check the applicability of other resistor values in each case.
 2) At bit rates lower than 1 Mbit/s the bus length may be lengthened significantly. Depending on l, the bit rate and internal capacitances of the individual ECUs, other network topologies with changed lengths l and d may be used. In this case the influence of occurring cable resonator waves on the bit representation on the bus line should be carefully checked by measurements of V_{diff} at each ECU (see also table 8, note 3).

Victor SPX User Guide

Star topology is **not** recommended. This use case is not common, nor is it suggested in the DW CAN bus specification. This nonstandard implementation requires careful study and analysis of the candidate bus cable, which is typically beyond the capabilities of a typical FRC team.

This topology may be used when performing basic testing on a bench-setup with a small network (few modules and short cable travel). However, this use case should not be construed as evidence guaranteeing that star topology is a robust solution. Star topology is not a robust general solution to be relied on for critical applications.

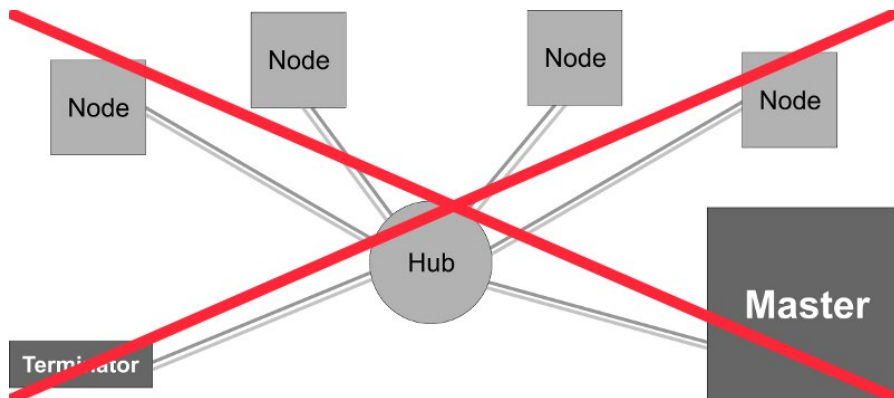

Ring topology is **not** recommended. This use case is not common, nor is it suggested in the DW CAN bus specification. This nonstandard implementation requires careful study and analysis of the candidate bus cable, which is typically beyond the capabilities of a typical FRC team.

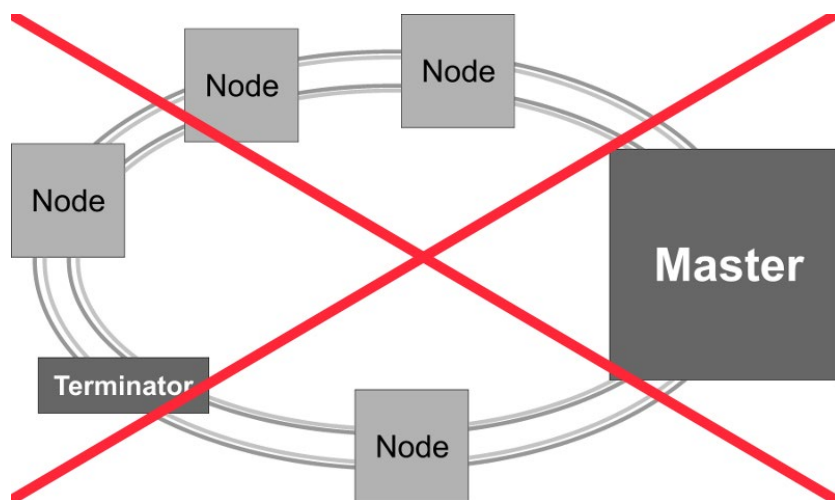

Troubleshooting

Indication: No ORANGE Status LEDs on power up.

Problem: Input power issue or joystick trim tab off center.

Possible Solutions:

1. Disconnect CAN cable(s).
2. If Status LEDs remains off, check +V or GND connections for voltage and proper polarity.
3. If Status LEDs blink ORANGE, the speed controller is probably damaged. The final test to determine if the Victor SPX is damaged to to replace it with another Victor SPX that is known to function properly.



CAUTION: PRIOR TO REPLACING A POTENTIALLY DAMAGED SPEED CONTROLLER, ENSURE THAT THE WIRES CONNECTED TO THE OUTPUT ARE NOT SHORTED AND THE INPUT IS NOT REVERSED. ALSO, VERIFY THAT NEITHER OF THE VICTOR SPX'S MOTOR OUTPUT LEADS ARE SHORTED TO THE CHASSIS OF THE MOTOR OR THE ROBOT.

Indication: Flashing ORANGE Status LEDs on power up.

Problem: No CAN/PWM signal.

Possible Solutions:

1. Ensure the transmitter and receiver are powered ON.
2. The CAN/PWM cable may be improperly connected. Check wire color-coding at each end. Check that the connector is not offset by a pin at the receiver end.
3. If using PWM, check for a good PWM signal by connecting a known good servo to the PWM cable. If the servo does not move, this can indicate either:
 - a. A faulty microcontroller
 - b. An improperly connected cable
 - c. A bad PWM cable

Note: The servo requires that voltage be present on the center pin of the PWM cable. This connection is not required for the Victor SPX.

Victor SPX User Guide

Indication: Flashing RED Status LEDs after calibration.

Problem: Calibration Failed.

Possible Solutions:

1. Inadequate travel in either the forward or reverse direction. Repeat the calibration procedure and move the joystick further forward and/or further reverse.
2. The joystick trim is not centered. Neutral cannot be extremely far from center.

Indication: No power output from the speed controller although the Status LEDs work.

Problem: Possible internal damage.

Possible Solutions:

If the Status LEDs on the Victor SPX are operating properly and there is no output, the Victor SPX may be internally damaged. This condition is typically caused by a short circuit on the output or there has been an over-current condition that caused a failure.

Check the following:

1. Ensure the Status LEDs are changing between ORANGE, RED, and GREEN with joystick movement.
2. Disconnect the motor and check the output (M+ to M-) with a voltmeter. The meter should read between +/- battery voltage with corresponding full range joystick movement. If the Status LEDs are working properly and the outputs are not working properly, the speed controller is probably damaged. The final test to determine if the Victor SPX is damaged is to replace it with another Victor SPX that is known to function properly.



CAUTION: PRIOR TO REPLACING A POTENTIALLY DAMAGED SPEED CONTROLLER, ENSURE THAT THE WIRES CONNECTED TO THE OUTPUT ARE NOT SHORTED AND THE INPUT IS NOT REVERSED. ALSO, VERIFY THAT NEITHER OF THE VICTOR SPX'S MOTOR OUTPUT LEADS ARE SHORTED TO THE CHASSIS OF THE MOTOR OR THE ROBOT.



Victor SPX User Guide

Indication: No power output from the speed controller and the Status LEDs do NOT work.

Problem: No input power or possible internal damage.

Possible Solutions:

If the Status LEDs on the Victor SPX are not operating properly and there is no output, the Victor SPX may be internally damaged. This condition is typically caused by no input power or a reversed polarity on the input.

Check the following:

1. Disconnect the output wires.
2. Ensure the Status LEDs on the Victor SPX do not illuminate at any joystick position.
3. Check the input at the Victor SPX (+BATTERY to GND) with a voltmeter. If the Status LEDs are not working properly and the input is good, the speed controller is probably damaged. The final test to determine if the Victor SPX is damaged is to replace it with another Victor SPX that is known to function properly.



CAUTION: PRIOR TO REPLACING A POTENTIALLY DAMAGED SPEED CONTROLLER, ENSURE THAT THE WIRES CONNECTED TO THE OUTPUT ARE NOT SHORTED AND THE INPUT IS NOT REVERSED. ALSO, VERIFY THAT NEITHER OF THE VICTOR SPX'S MOTOR OUTPUT LEADS ARE SHORTED TO THE CHASSIS OF THE MOTOR OR THE ROBOT.

FCC Compliance Statement (United States):

This device complies with part 15 of the FCC Rules. Operation is subject to the following two conditions:

- (1) This device may not cause harmful interference, and
- (2) this device must accept any interference received, including interference that may cause undesired operation.

Changes or modifications not expressly approved by the party responsible for compliance could void the user's authority to operate the equipment.

Note: This equipment has been tested and found to comply with the limits for a Class B digital device, pursuant to part 15 of the FCC Rules. These limits are designed to provide reasonable protection against harmful interference in a residential installation. This equipment generates, uses and can radiate radio frequency energy and, if not installed and used in accordance with the instructions, may cause harmful interference to radio communications. However, there is no guarantee that interference will not occur in a particular installation. If this equipment does cause harmful interference to radio or television reception, which can be determined by turning the equipment off and on, the user is encouraged to try to correct the interference by one or more of the following measures:

- Reorient or relocate the receiving antenna.
- Increase the separation between the equipment and receiver.
- Connect the equipment into an outlet on a circuit different from that to which the receiver is connected.
- Consult the dealer or an experienced radio/TV technician for help.

ICES-003 Compliance Statement (Canada):

This Class B digital apparatus complies with Canadian ICES-003.

Cet appareil numérique de la classe B est conforme à la norme NMB-003 du Canada.

Revision History:

2018/05/31 - Initial Public Release

2021/11/29 - Added PWM voltage and current info